

Scharfer

Professional LED power supplies

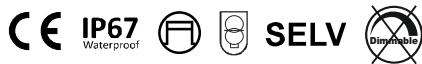

Model: **SCH-300-12** Size: 257*90*40mm
SCH-300-24



Brief Information

Powermax™
Technology Inside

300W

Waterproof Power Supply (C.V.)

Model SCH-300-12 / SCH-300-24

Input 190-250V AC

Output 12VDC 25A 300W / 24VDC 12.5A 300W

Product Features

- High transfer efficiency
- Stable constant voltage output
- IP67, both indoor & outdoor use suitable
- 100% full loading, 100% burn-in tested
- Overload/short circuit protection

MAIN ELECTRICAL DATA

AC Input

Input Voltage	190-250V AC
Input Frequency	50/60Hz
Efficiency (Typ.)	>89%
Input Current	230V: 2.5A max.
Inrush Current	40A
Leakage Current	5mA/230VAC

DC Output

Output Voltage	12V	24V
Rated Current	25A	12.5A
Rated Power	300W	300W
Ripple & Noise (Max.)	<200mVp-p	<200mVp-p
Setup, Rise Time	1500ms/230VAC	1500ms/230VAC
Line Regulation	1%	1%
Load Regulation	1%	1%

Service Environment

Working Temp.	-30°C~50°C
Working Humidity	20~99%RH
Storage Temp.	-40°C~80°C
Storage Humidity	10~99%RH

Protection

Overload	Yes, cut-off mode, output cut-off if 5-30% overloaded, automatic recovery
Short Circuit	Yes, cut-off mode, recovers automatically after fault condition is removed

Safety

Safety Standard	EN 61347-2-13
Withstand Voltage	I/P-O/P: 3000VAC/1min/<5mA
Isolation Resistance	I/P-O/P: >100M Ohms / 500VDC / 25°C / 70%RH

Packaging Information

Product Dimension	257*90*40mm
Products Net Weight	1570G
PCS/Carton(QTY)	10 PCS
G. Weight/ Carton	17KG
Carton Dimension	32*25*25.5cm

Installation Tips:

- Please identify the power supply's input and output before installation.
- Ensure correct output + & - wire connection. Power on after wire connection is done.
- To avoid voltage drop and loading capacity wasting on the output extension wire, please install the power supply to the loading as near as possible, if must use long extension wires, thicker wires and less loading wattage is required.
- The power supply to be installed at good ventilation and cooling environment.

Scharfer

Professional LED power supplies

Physical Drawing

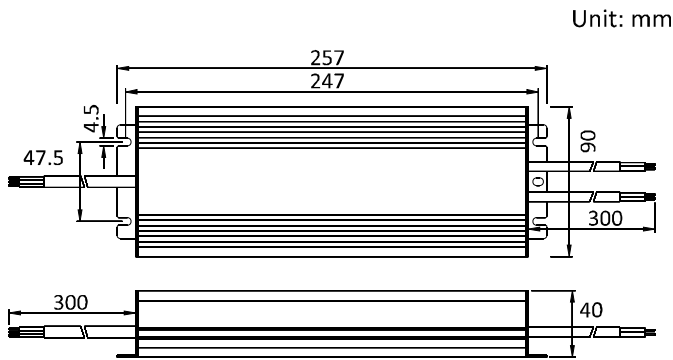

Brief Information

Powermax™
Technology Inside

300W

Waterproof Power Supply (C.V.)

Model SCH-300-12 / SCH-300-24

Input 190-250V AC

Output 12VDC 25A 300W / 24VDC 12.5A 300W

Input: 3x1.0mm² wire, Brown L, Blue N
300mm length

Output: 2x1.5mm² wire, Red +, Black -
300mm length, 2 outlets

Housing: Aluminium

Block Diagram

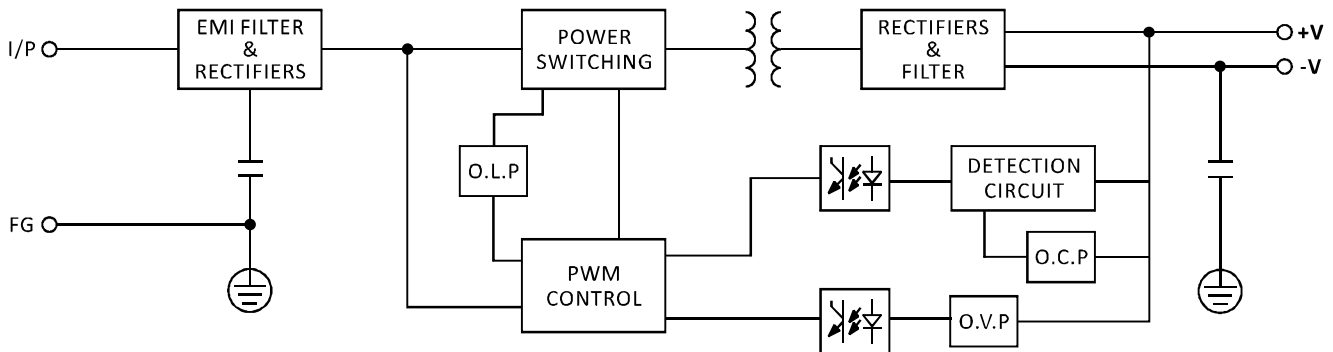

Derating Curve

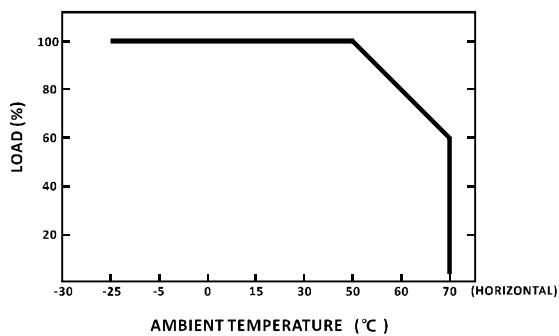

Static Characteristics

